



MASH tested

Key features

- Convenient dual-lifting points
- Free of internal corrodible components
- Short system length
- Empty or full handling
- Self-centering J-slot hinge for movable barrier applications
- Identical absorption elements
- Universal transition
- No foundation required
- No ground anchoring needed
- Designed for warm and cold weather

Product Description

The Quash crash cushion distinguishes itself as one of the safest MASH-tested, non-redirective systems on the market. It boasts a user-friendly design and has minimal components to ensure easy handling, installation, and maintenance. Notably, it is the first system designed to safeguard movable barriers as well as portable temporary barriers.

PATENT PENDING



Specifications

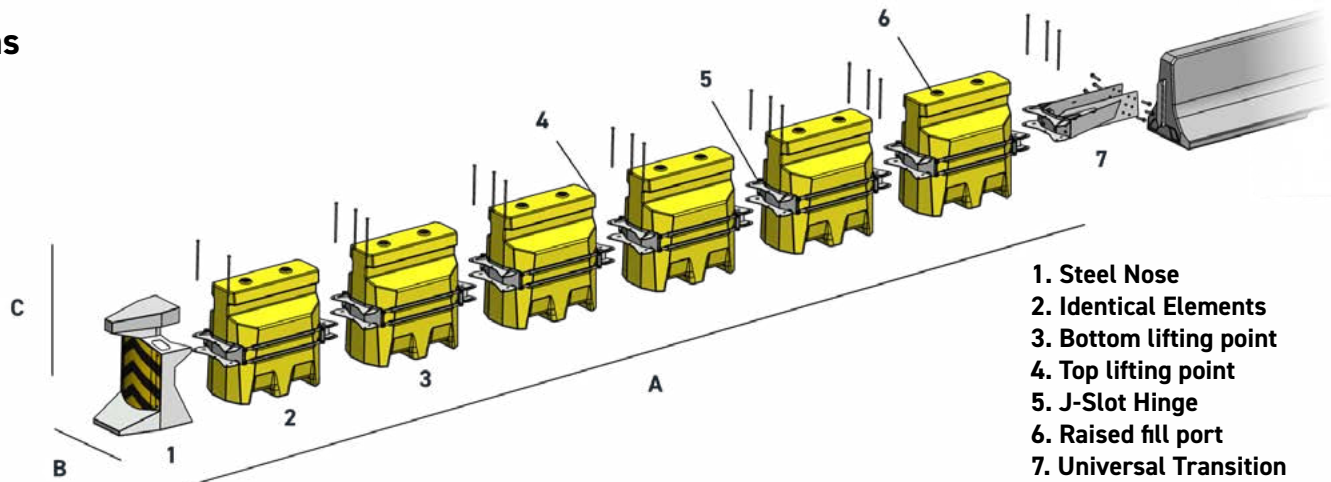

1. Steel Nose
2. Identical Elements
3. Bottom lifting point
4. Top lifting point
5. J-Slot Hinge
6. Raised fill port
7. Universal Transition

	MASH TL-2	MASH TL-3
LENGTH (A)	16.7 ft (5.1 m)	24 ft (7.3 m)
WIDTH (B)	24 in (610 mm)	
HEIGHT (C)	42 in (1.07 m)	
VOLUME PER FULL ELEMENT	450 L (119 gal)	
WEIGHT EMPTY ELEMENT	140 lbs (63.5 kg)	
WEIGHT WATER FILLED ELEMENT	1132 lbs (513.5 kg)	
COMPATIBLE BARRIER END TREATMENT WIDTH	9.5 in to 13.75 in	

MASH tested

The Quash has undergone successful MASH testing to ensure maximum safety. These tests rigorously assess impact performance and stability, protecting drivers and passengers in the event of a crash.

Watch the video at moovop.com

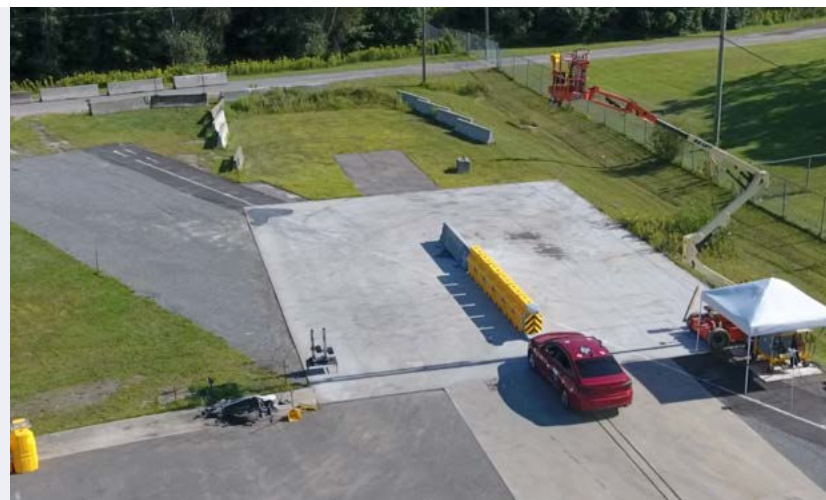

Distributed by

